

# STAGEMAKER CONTROLLERS



## INSTALLATION

## MAINTENANCE

**STAGEMAKER CONTROLLER**  
***SERIES R-FL.. PRMSR***

 **VERLINDE**  
LIFTING EQUIPMENT

**Herewith we,**

**VERLINESA**, 2 bd de l'Industrie, BP 59,  
F-28501 VERNOUILLET Cedex, Frankrijk

*Declare that the product*

**STAGEMAKER CONTROLLER**

Manufacturing date : .....

Serial No. : .....

**This equipment is to be used in corporation with other machines. It cannot be put into operation until the systems of which it is a part, has been declared as conforming to the provisions of the directive:**

Machines 89/392 EEG, 91/368 EEG, 93/44 EEG, 93/68 EEG

Electric machines 73/23 EEG,

Electromagnetic compatibility 89/336 EEG, 91/263 EEG, 92/31EEG, 93/68 EEG

**As well as harmonised norms, in particular EN292, chapter 1 and 2 (safety of machines),**

Applied technical standards and specifications, in particular:

IEC 34-1 "Rotating electrical machines"

IEC 34-5 ""Rotating electrical machines"

IEC 947-5-1 "Lowvoltage switchgear and control gear"

IEC 364 "Electrical installations of buildings"

EN 60204 "Safety of Machines"

The party carrying out the integration will state these passages in declaration of conformity of the machines, the party will add the regulations and standards to the final installation "machine" and has to comply with, the party carrying out the integration will draw up the corresponding technical file.

VERLINESA,  
VERNOUILLET, 1-11 -2001

## CONTENT

<i>chapter</i>	<i>description</i>	<i>page</i>
1	Introduction	3
2	What to do - What not to do	5
3	Guarantee	6
4	Identification	7
5	Functional description	8
6	Trouble shooting	11
7	Specifications	11
Attachments general layout drawings		
	<ul style="list-style-type: none"><li>• R4PRM SR</li><li>• R8PRM SR</li><li>• R12PRM SR</li></ul>	
Electrical diagrams		
	<ul style="list-style-type: none"><li>• R4PRM SR</li><li>• R8PRM SR</li><li>• R12PRM SR</li><li>• FL8PRMLV SR</li><li>• FL12PRMLV SR</li></ul>	

## 1 INTRODUCTION:

The STAGEMAKER® controllers with radio remote series R..PRM SR and FL..PRMLV SR has been developed specifically for the control of VERLINDE STAGEMAKER® chain hoists (motors) series SM5 and SM10 version A for direct control. The controller series R..PRM SR and FL..PRMLV SR are available with 4, 8 OR 12 channels and built into a compact suitcase, 19" rack casing.

These controllers allows you to control the chain hoists individually or simultaneously with one single button. Pre-selection facilities for all units, on the controller series R..PRM SR and FL..PRMLV SR front as well on the remote box that incorporate red and green LED indicators, which indicate the selected hoisting direction.

For larger applications, controllers series R..PRM SR and FL..PRMLV SR could be wireless interconnected to serve a system up to 16 motors from one single remote box.

STAGEMAKER® controllers series R..PRM SR and FL..PRMLV SR fully meet the latest European electrical standards (IEC-EMC) and have been approved by the official APAVE institute. They offer a maximum flexibility, durability and safety.

### **Version A controller series R..PRM SR for direct controlled hoist:**

- Combination of power switching through a unique solid state PC board
- Main contactor
- Mushroom emergency button with mechanical interlock
- Individual up/down selectors per motor
- Short circuit protection in main circuit by means of automatic fuses
- Phase reverse facility on incoming CE plug
- Automatic thermal control on each channel
- Phase reverse facility for each channel
- LED indicators for incoming phases
- Mutly connectors each to serve 4 hoists
- Single cable connections between controller series R..PRM SR and hoists
- Channel selection mode
- Frequency selection mode

### **Version B controller series FL..PRM LV SR for contactor controlled hoist:**

- All features as mentiond above
- In dividual CEE connectors for power (red)and control (yellow)
- Twin cable connections between controller series FL..PRMLV SR and hoists

## 2 WHAT TO DO

- Mount the controller in a protective casing, (if standard casing is not supplied).
- Handle the controller by its grips at the front or at side.
- Store the controller in its normal operating position away from aggressive atmospheres (*dust, humidity...*).
- Make sure that the controller is always clean and protected from corrosion.
- A technician should install the controller with the necessary competence.
- Make sure that connecting cables are in good condition and connectors are fitted properly.
- Make sure that connecting cables are always symmetrical fitted
- If one hoist direction doesn't match with the Up / Down indicators on the controller, check intermediary cabling and change two phases.
- If all hoists do not match with the indicators, change phases by means of phase reverse facility in the CE plug or with the reverse switch.
- Use only original parts in case of replacements.
- Always be ready during the operation to press the emergency stop button. This makes all functions inactive.
- Before operation, check that the load is correctly fastened and installed on the hook. The hook safety catches should be closed correctly.
- Make sure that the load is correctly balanced before moving it.
- Make sure that each hoist is vertical to the load and hanging free on its load chain, before starting a simultaneous operation.
- If used out door, use sufficient protection against bad weather conditions.
- Switch to another frequency of normal operation is disturbed frequently.
- Use the material under normal working conditions (*ambient temperature, atmosphere...*).
- Moving a single load or truss system requires experienced operators.
- All the necessary precautions should be taken to ensure a correct the distribution of the load and to avoid overloading a single hoist in set of multiple uses. The hoists should be carefully checked individually before such an operation.
- Notify the responsible and competent person after a dangerous operation or if the hoist seems problematic

*(Abnormal noise, abnormal behaviour...).*

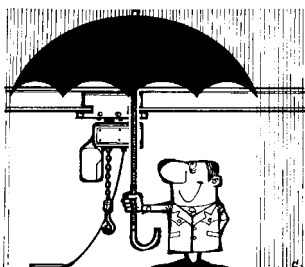

*Material used outdoors should be protected as well as possible against bad weather conditions.*

## WHAT NOT TO DO

- Never connect a STAGEMAKER controller to a power source other than specified on the unit.
- Do not set down the controller without having an adapted support, to avoid damaging the components on the rear
- Never modify the controller unless the constructor has studied and authorised the modification.
- Never modify the values and adjustments of the safety components, outside the limits provided for in the manual, or without the approval of the constructor.
- Never try to repair or intervene on the controller without the authorisation of the constructor or a qualified electrician.
- Do not let an unqualified person use the controller.
- Never connect more hoists than the available number of outlets (channels) or number of selector switches available.
- Do not use additional splitters to connect more than one hoist per channel.
- Avoid shocks or accidental collision with other objects.
- Never open the controller as long as the system is under power.
- Never block, or lock the RUN button in order to continue a movement without manual interference.
- Do not operate the controller if your physical condition does not allow it.
- Never use the controller series if it is in bad condition.
- Never use suspected spare parts or parts whose origin is not known.
- Do not subject the controller to brutal shocks.
- Never distract the operator's attention while he is being operating the system.
- Do not use the controller for a purpose or in an area for which it is not intended.
- Do not expose the controller to an aggressive atmosphere (*temperature, acidity...*)
- Do not use the safety components as operation components (*emergency button, main fuse switch. etc..*)
- Do not use the controls needlessly (avoid inching - stop-start operation of the buttons). This can cause overheating and even damage to the hoist.
- Do not change the hoisting direction whilst the RUN button is pressed (hoist under power)
- If hoist direction doesn't match with the indications on the controller, don't change phases inside the controller but exchange two phases on the hoist motor or the interconnecting cables.
- Never use hoists who are running in the opposite direction of the selected motion.
- Do not connect the controller to an unknown power supply, check if power source matches the specification of the controller and the hoists. (*under voltage or over voltage +/- 5%, absence of phase etc...*).

### 3 GUARANTEE

Our STAGEMAKER controller series R..PRM SR and FL..PRMLV SR are guaranteed **for one year** from the date of delivery.

If for a reason outside the control of the vendor, the delivery is delayed, the time lag cannot exceed three months.

If the use (*installation*) of the controller is delayed, the corresponding extension of the guarantee (a single extension limited to three months) must be requested, and written confirmation obtained.

The vendor undertakes to eliminate all operating errors originating from the concept, the execution, the components or the materials themselves.

**The guarantee does not cover normal wear, or the failures resulting from abnormal use. It does not cover damage due to a lack of supervision, to false operation or to a bad utilisation of the controller, particularly due to overload, inching, under voltage or over voltage or connecting errors.**

The guarantee does not apply when there is disassembly, modification or replacement of parts (*mechanical or electrical*) by an unauthorised party or without our prior agreement.

The guarantee only applies for original, factory-installed spare parts.

For the duration of the guarantee, the vendor undertakes to replace or repair, free of charge, the parts, in his workshop, that are acknowledged to be damaged following examination by a qualified and authorised technical service.

The guarantee excludes any other services or indemnities. The repairs covered by the guarantee are carried out, as a rule, in the workshops of the vendor or authorised agent. When servicing of the equipment is done outside these workshops, the labour costs for disassembly or assembly of these parts are borne by the vendor when these are done exclusively by his staff or by an authorised agent. The replaced parts become the property of the vendor and must be returned to the vendor at his expense.

For components of a relative particular importance that are not manufactured by the vendor and which carry the brand name of specialised manufacturers, the manufacturer's guarantee (which can vary according to the manufacturer) is applicable.

\* The guarantee does not apply for expendable parts defined by the manufacturer:

- Fuses
- Contactor contacts
- Batteries

#### 4 IDENTIFICATION:

##### Type codes

Type	No. of channels	Subscription	Housing	Hoist connection
R4PRM SR	4	Direct control + remote	19" 3U rack in flight case	multi-plug rear side
R8PRM SR	8	Direct control + remote	19" 3U rack in flight case	multi-plug rear side
R12PRM SR	12	Direct control + remote	19" 6U rack in flight case	multi-plug rear side
FL8PRM LV SR	8	Lowvoltage control + remote	19" 12U in flight case	CEE plugs rear side
FL8PRM LV SR	12	Lowvoltage control + remote	19" 12U in flight case	CEE plugs rear side

##### Location of controls and connections

Subscription	On rack	On remote
Main switch	yes	-
Power indicators	yes	-
Emergence stop with mechanical interlock	yes	yes
Up / Down selector switches	yes	yes
Channel selection switch	yes	yes
Reset	-	yes
Green RUN button	yes	yes
Main & secondary fuses	yes	-
Thermal protection per hoist	yes	-
Frequency mode selector switch	yes	yes
Main power entry 16 amp CE-5p & 0.5 m cable	rear; R4..	-
Main power entry 32 amp CE-5p & 0.5 m cable	rear; R8..R12..	-
Multi connectors for hoists output 16 pin -16Amp	Rear R models	-
CEE connector for hoists output power 4pin -16Amp red male	Rear FL models	-
CEE connector for hoists output control 4pin -16Amp yellow female	Rear FL models	-
Local remote switch	yes	-
Default indicator with reset	yes	-
Phase reverse switch	Yes	-



## 5 FUNCTIONAL DESCRIPTION

### Cable connections:

- Connect an external power source with the main CE power plug. Be sure that the nature of this source corresponds to the supplied equipment, such as mentioned aside of the plug.
- Connect the chain hoists through fan-out or multi cables with the controller series R..PRM SR's outlets. Controller series FL..PRM SR do have separate single cables for power and control.

**Warning:** Use only cables and connectors who are in good condition, inferior connections might cause severe damage of the equipment and electric motors.

**Connecting more than one SM10 or two SM5 hoists per channel might cause severe damage of the equipment.**

### Operation:

- Release the emergency switch by turning anti-clockwise.
- Set the local / remote switch in the required position. Local in case of control by means of the up/down selector switches on the controller and remote if the radio remote handheld is being used.
- If handheld is used:
  - set the channel selector in the same mode as indicated on the display of handheld.
  - set the group mode selector in the correct mode. (see group mode selection table)
  - See "REMOTE OPERATING INSTRUCTIONS" for details.
- Use the selector switches to set the hoists in the upper or lower mode.
- Push the RUN button to activate the pre-selected hoists.
- Check if the hoist direction matches the selected mode. If not reverse, phases by means of the phase reverse switch.

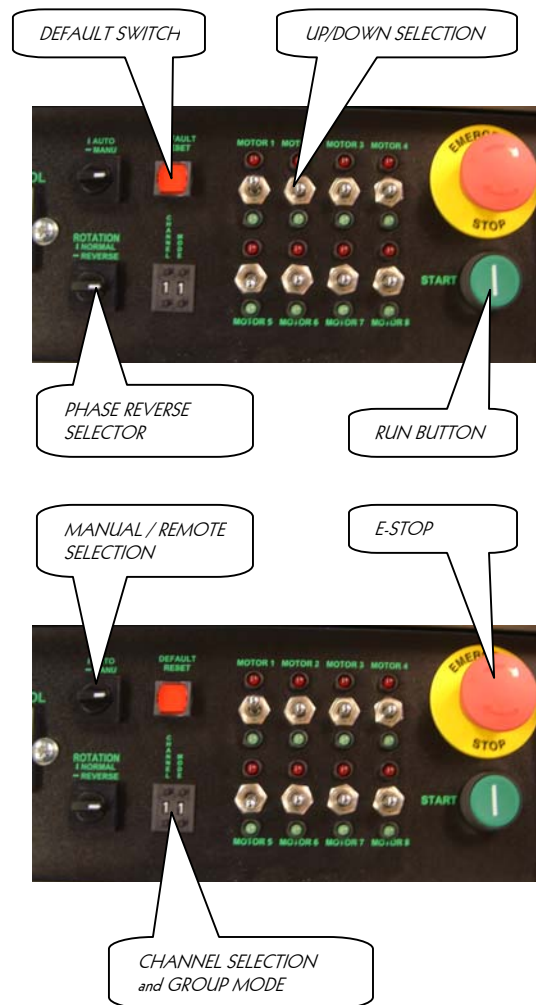

### Group mode selection:

Since the radio remote handheld has 16 channels as a standard, it is possible to use different configurations of controllers. For that purpose the controllers have a mode selector. The setting of this selector should be in accordance to under mentioned table.



GROUP MODE SELECTION

Group mode selection table

Number of controllers	Number of channels on each controller	Mode selection no. controller 1	Mode selection no. controller 2	Mode selection no. controller 3	Mode selection no. controller 4
1	4	1, 2, 3 or 4	-	-	-
1	8	5 or 6	-	-	-
1	12	7	-	-	-
1	16*	8	-	-	-
2	4 and 4	1	2	-	-
2	4 and 4	3	4	-	-
2	4 and 8	3	5	-	-
2	4 and 12	4	7	-	-
2	8 and 8	5	6	-	-
3	4, 4 and 4	1	2	3	-
4	4, 4, 4 and 4	1	2	3	4

\*not yet available

### Notes:

- Phase sequence could also be reversed by means of changing two phase-pins fitted on a satellite inside the 32Amp CE connector. Push and turn the satellite with screwdriver 180 degrees.
- There are three pre-selection modes; upper, lower or zero modes. Only pre-selected hoists in upper or lower mode will come in to the corresponding operation.
- If circumstances require doing so, push the RED button in order to stop all hoists immediately. Release this button by turning it anti clockwise.
- **Don't change the hoist direction whilst motors are under power. Release first the RUN button, make your changes and push the RUN button again.**
- If a hoist output has been thermal overloaded, or there are interfering signals, the controller will stop all motions and go to the standby mode. A red warning indicator in the front will light. Pushing the red indicator light makes reset.

## REMOTE OPERATING INSTRUCTION

R	=	reset
▲	=	motion Up
S	=	select
C	=	confirm
D	=	deselect
▼	=	motion Down

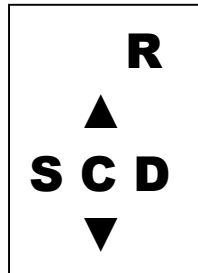

### Starting procedure:

The controller has to be in the standby mode with selector switch set to “auto”

Pull out the red emergency stop button on the remote

Push simultaneous on **S** and **C**

Communication is valid if the channel indicator shows the same channel number as selected on the controller. For valid confirmation there is a short “bib” sound.

If there is no communication the “bib” sound remains.

### Frequency selection:

Under certain circumstances radio interferences might disturb normal operation as a consequence of which the radio remote will be switched off. It therefore has been equipped with 8 different frequencies. Select an other frequency if communication is disturbed regular in the following manner:

Push the three vertical buttons ▲ **C** ▼ at the same time to open the frequency selection menu.

The value in the display starts to blink on off.

Press ▲ to increase the number or ▼ to decrease the number while it is blinking.

Press **C** to confirm the new selection. The display remains at the new setting.

Set the channel indicator on the controller in the same mode by pressing on the button next to it.



CHANNEL SELECTION MODE

**Note:** The remote box has 4-penlight batteries type AA 1.2 volt.

A bib signal alarms in case of low batteries.

In case of replacement, open the grip with a screwdriver.

**Hoist selection - add:**

Select hoist by pressing on **S** once (both LED's up/down lit) and press **▲** or **▼** once for selection of motion. The corresponding LED remains lit. Press **C** for confirmation, the corresponding LED will light.

Repeat this for all hoists that are to be added; Use **S** and **D** to scroll through the available channels and press **C** for confirmation.

**Hoist selection - remove:**

Select hoist by pressing on **D** once (both LED's up/down lit) and press **▲** or **▼** once for selection of motion. The corresponding LED remains lit. Press **D** for confirmation, the corresponding LED will light.

Repeat this for all hoists that are to be added; Use **D** and **S** to scroll through the available channels and press **C** for confirmation.

**Output selection - normal or inverted:**

Select hoist by pressing on **S** once for hoist No. 1, twice for No. 2 etc; press **C** and **D** at the same time once, the pre-selected hoist motion LED starts flashing. Press **▲** the LED will indicate "n" (normal) or **▼** the LED will indicate "i" (inverted). Press **C** once for confirmation, the corresponding LED remains flashing as long as the output is inverted.

Repeat this for all hoists that are to be selected.

**Note:** *change of output selection should be done after hoist selection.*

**RUN mode:**

Once hoists have been selected and confirmed, hold pressure on the left or right **RUN** button to activate the hoist(s). The corresponding LED will light. Release the **RUN** button to stop the motion. If this button is released for more than 20 seconds, the function is discharged and **C** has to be pressed once again to re-confirm the latest selection before the **Run** button will be active again.

**Change of Up/Down motion:**

To change the motion, once hoists and output have been selected, press the **▲** for up or **▼** for the lowering motion. The motion of all selected hoists will be altered consequently without confirmation, provided that the **RUN** mode is active. If the **RUN** mode is de-activated meanwhile, press **C** for re-confirmation of the new selection.

Press the **RUN** button to continue the operation.

**Reset:**

Press **reset** to clear all settings.

**Emergency stop:**

In case of emergency, press down the red **E-stop** button, all motions will stop immediately and all settings will be cleared.

R model CONTROLLERS

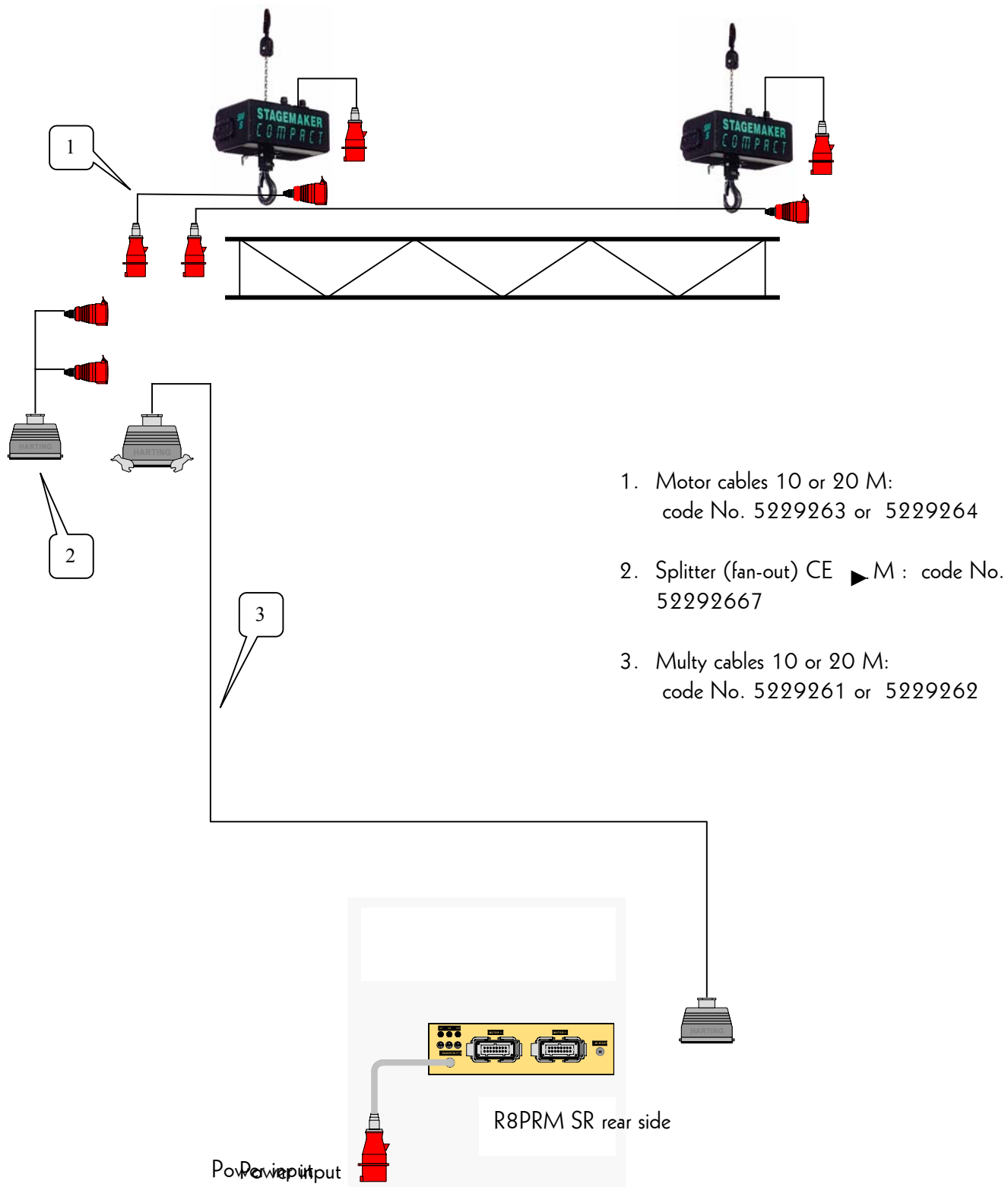

FL model CONTROLLERS

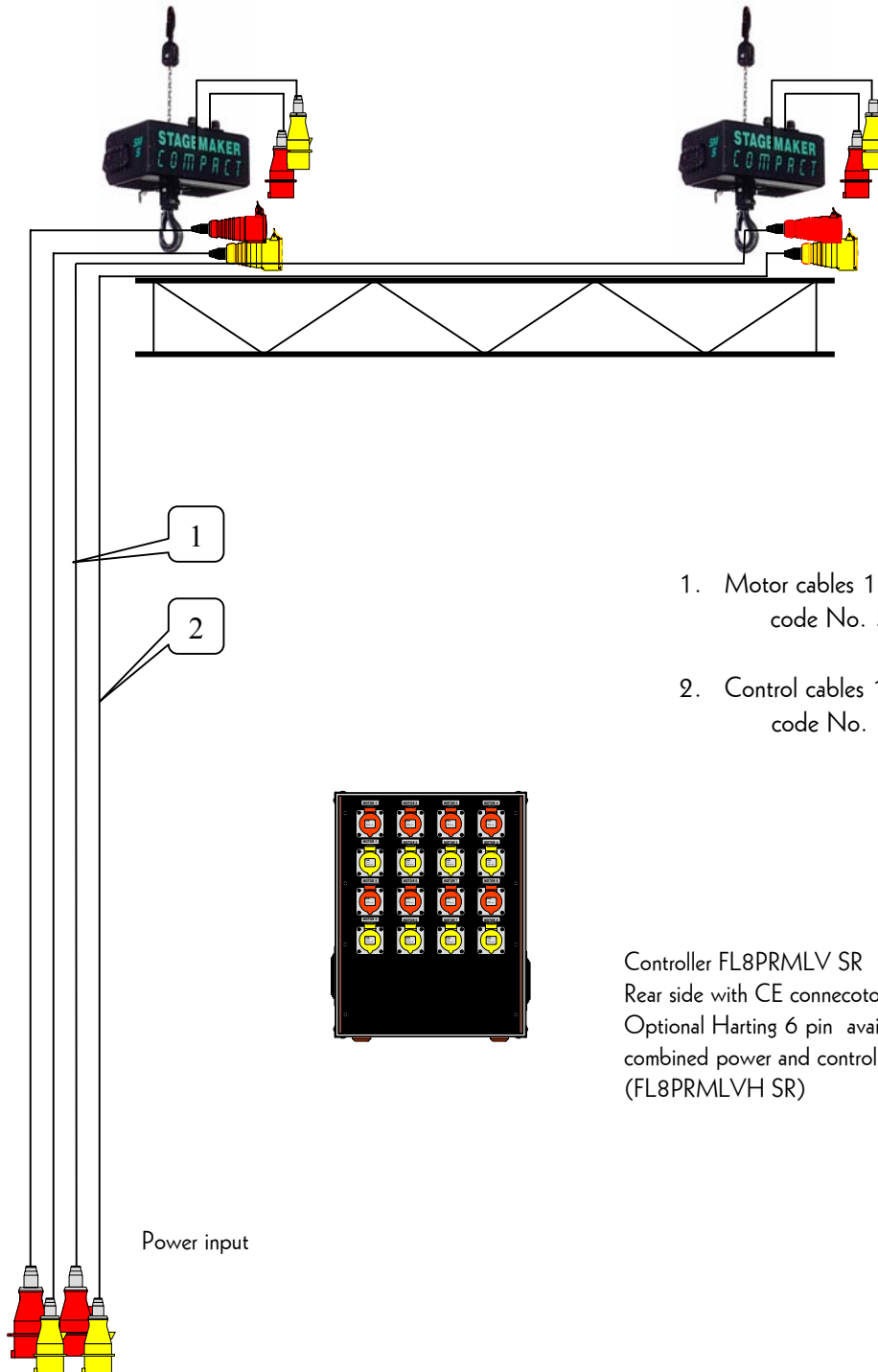



1. Motor cables 10 or 20 M:  
code No. 52292663 or 52292664
2. Control cables 10 or 20 M:  
code No. 5229853 or 5229854

Controller FL8PRMLV SR  
Rear side with CE connectors  
Optional Harting 6 pin available for  
combined power and control.  
(FL8PRMLVH SR)

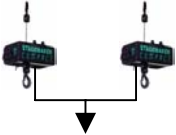

## 8 CABLE SELECTION TABLE

The table hereunder gives an indication of the maximum length of cables between controller and hoist (motor). They are calculated in accordance to NE 60 204 and worse case consideration

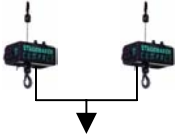
①

	1.5mm <sup>2</sup> or 1.5 <sup>2</sup> mm <sup>2</sup> + 2.5mm <sup>2</sup> sections					
	400V/50Hz			230V/50Hz		
	L max (m)		In Max (A)	L max (m)		In Max (A)
						
SM1	230	115	1.4	75	35	2.5
SM5	100	50	3.2	40	20	4.5
SM10	65		1.75	25		7

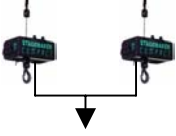
②

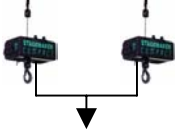
	2.5mm <sup>2</sup> sections					
	400V/50Hz			230V/50Hz		
	L max (m)		In Max (A)	L max (m)		In Max (A)
						
SM1	255	125	1.4	80	40	2.5
SM5	110	55	3.2	45	20	4.5
SM10	75	35	1.75	25		7



### Limitations

Cable with different section, i.e. 1.5mm<sup>2</sup> and 2.5mm<sup>2</sup>, can be connected together. But maximum length of cable depends of the smallest section. That is why if a cable assembling contains both 1.5mm<sup>2</sup> and 2.5mm<sup>2</sup> cable section you should refer to chart ①. If the cable assembling contains only 2.5mm<sup>2</sup> section you should refer to chart ②.

Those charts have been calculated according to EN-60-204 with a maximum voltage drop of 5%.

## 9 OPTIONAL EXTRA'S

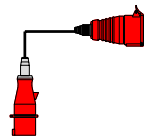
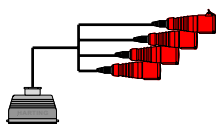
## Accessories for R..PRM SR controllers

<i>Code</i>	<i>Function drawing elec. dwg</i>	<i>Length (m)</i>	<i>Section (mm<sup>2</sup>)</i>	<i>Plugs</i>	<i>Symbol</i>
52292663	Motor extension cable SMCA-04P-04P-100	10	4G2.5	CEE 3P+T Male – Female	
52292664	Motor extension cable SMCA-04P-04P-200	20			
52292667	Splitter (fan-out) SMCA-16P-04P-005-2	0.5	4x1.5	16P+T – CEE 3P+T male – female	
52292669	Control-box (pickle) with E-Stop SMBA-04P-04P-005 Z3015101	0.5	4x1.5	CEE 3P+T – CEE 3P+T Male – female	
52292661	Extension 4 motors SMCA-16P-16P-100	10	16x1.5	16P+T – 16P+T male – female	
52292662	Extension 4 motors SMCA-16P-16P-200	20			

## Accessories for FL..PRMLV SR controllers

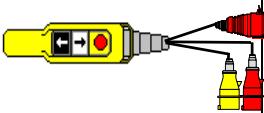
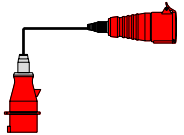
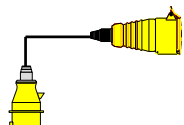
52293740	<i>Control box B (pickle) with E-stop</i> SMBA-04P-HOI-005 Z3015103	0.5	4x15	CEE 3P+T Femelle	
52292663	<i>Motor extension cable</i> SMCA-04P-04P-100	10	4G2.5	CEE 3P+T Male – Female	
52292664	<i>Motor extension cable</i> SMCA-04P-04P-200	20			
52292853	<i>Control extension cable</i> SMCA-04P-04P-A1	10	2.5	CEE 3P+T Male – Female	
52292864	<i>Motor extension cable</i> SMCA-04P-04P-A1	20	2,5		



## 10 CABLE CONNECTION DATA

### Controllers R.. and FL.. single motor cable with CEE plugs for power

Wires	Colour	Pin n°
L1 / U1	brown	1
L2 / V1	blue	2
L3 / W1	black	3
PE	yellow/green	PE

### Controllers R.. fan-out

Wires	Colour	Pin n°
L1	brown	1
L2	blue	2
L3	black	2
GND	yellow/green	4
L1	brown	5
L2	blue	6
L3	black	7
GND	yellow/green	8
L1	brown	9
L2	blue	10
L3	black	11
GND	yellow/green	12
L1	brown	13
L2	blue	14
L3	black	15
GND	yellow/green	16+PE

### Controllers FL.. single cable with CEE plugs for control

Wires	Colour	Pin n°
Common	brown	1
Motion Up	blue	2
Motion Down	black	3
PE	yellow/green	PE

### Controllers R.. multi cable, extension cable for 4 motors

Wires	Wire n°	Pin n°
L1	1	1
L2	2	2
L3	3	2
GND	4	4
L1	5	5
L2	6	6
L3	7	7
GND	8	8
L1	9	9
L2	10	10
L3	11	11
GND	12	12
L1	13	13
L2	14	14
L3	15	15
GND	16	
	16+PE	

### Controllers FL.. single cable with Harting plugs for power & control

Wires	Pin n°
L1	1
L2	2
L3	3
Common	4
Motion Up	5
Motion Down	6
PE	yellow/green
	PE

**Note :**

*These tables should be respected at any time to avoid damage to the hoists or controllers !*

## 11 TROUBLE SHOOTING

<p>If your controller doesn't work,</p> <ul style="list-style-type: none"> <li>• the power source</li> <li>• the fuses</li> <li>• thermal protection</li> <li>• if the emergency button is pressed</li> <li>• pre-selection switch settings</li> <li>• output cables</li> <li>• channel selector</li> <li>• manual – remote switch</li> <li>• batteries in remote set</li> </ul>	<p>—————→</p>	<p>check;</p> <ul style="list-style-type: none"> <li>: all three lamps should blink</li> <li>: switch bar in upper mode</li> <li>: red default lights</li> <li>: turn anticlockwise and pull</li> <li>: up or down mode</li> <li>: connected</li> <li>: in correct mode</li> <li>: in correct position</li> <li>: charged</li> </ul>
--	---------------	--

***Warning:** Before going in the panel it self, or removing the top plate, first disconnect the main power entry plug.*

## 12 SPECIFICATIONS

<ul style="list-style-type: none"> <li>• <b>Power supply</b></li> <li>• Controls direct switching models</li> <li>• Controls remote switching models</li> <li>• Maximum switching capacity</li> </ul>	<p>:</p> <p>:</p> <p>:</p> <p>:</p>	<p><b>400Vac-3f – 50 Hz</b> <b>or 230Vac-3f – 50Hz</b></p> <p>solid state with contactor output</p> <p>radio</p> <p>1.75 kW per channel at 400 V</p> <p>0.9 kW per channel at 230 V</p>
---	-------------------------------------	---